

NIRSPEC UAN ANALYZER

ON-LINE ANALYSIS OF
UREA AMMONIUM NITRATE COMPOSITION

- INCLUDING BIURET -

FEATURES

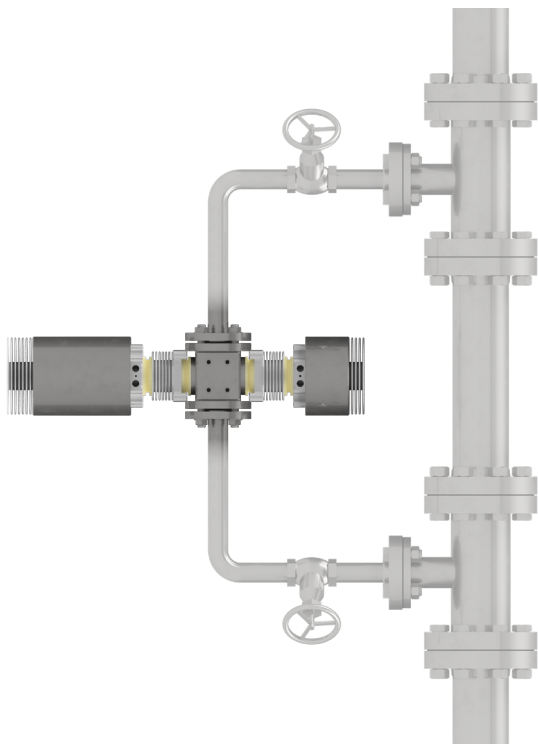

On-line measurement of 4 UAN components:
Urea, Ammonium Nitrate, Water and Biuret

Durable industrial design

Accuracy up to 0.1% wt.

Turbidity compensation

Compensation for product temperature
variation

Low sensitivity to optical window fouling

Automatic washing/cleaning of optical
windows

Operating pressure up to 10 bar

Operating temperature up to 120 °C

RS485 MODBUS interface

IP68 rating

PROCESS ANALYTICAL TECHNOLOGY SOLUTIONS
FOR ON-LINE/ IN-LINE/ AT-LINE ANALYSIS
AND MONITORING OF INDUSTRIAL PROCESSES

SPRANA
PROCESS ANALYTICAL TECHNOLOGY

NIRSPEC UAN PROCESS ANALYZER



The state of the art solution for on-line analysis of the composition of Urea Ammonium Nitrate.

NIRSpec UAN analyzer can measure not only the concentrations of the main UAN components: Urea, Ammonium Nitrate and Water, but also the concentration of the unwanted by-product Biuret, which is becoming an increasingly important quality parameter of UAN.

Accurate continuous/real-time measurements and the unique capability of measuring the concentration of Biuret enable a better control of the quality of the UAN in the production process.

The analytical technology is based on the Near Infra-Red spectroscopy and the state of the art proprietary multivariate calibration.

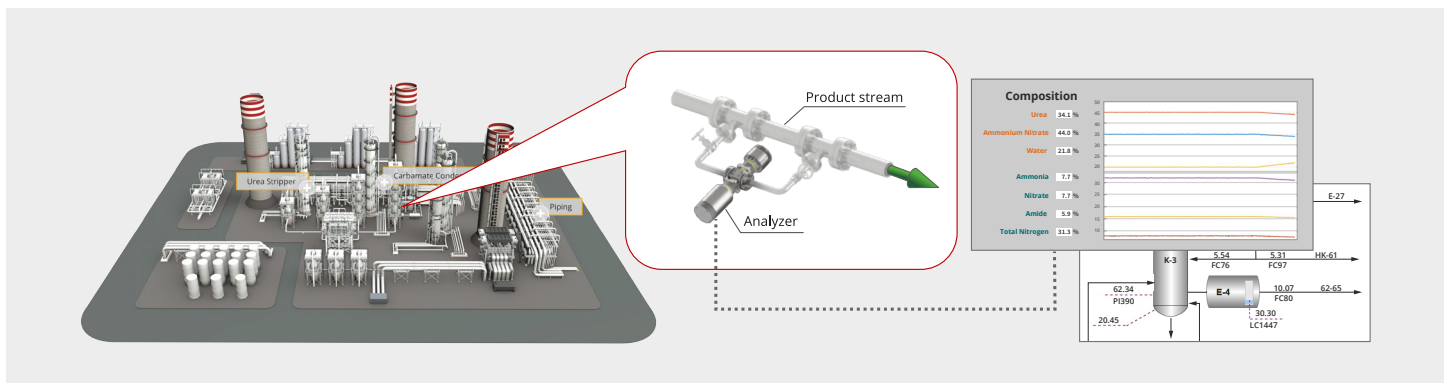

BENEFITS

Continuous on-line quantitative analysis of UAN for better process (product quality) control

Measurement of 4 UAN components: Urea, Ammonium Nitrate, Water and Biuret

Eliminates time-loss and cost for sampling and laboratory measurements

High accuracy, repeatability and stability

Low operating and maintenance costs

State of the art (proprietary) multivariate calibration with compensation for product temperature variation and for turbidity

Large transillumination area, hence less sensitivity to optical window fouling, better repeatability

NIRSPEC VS LAB COMPARISON

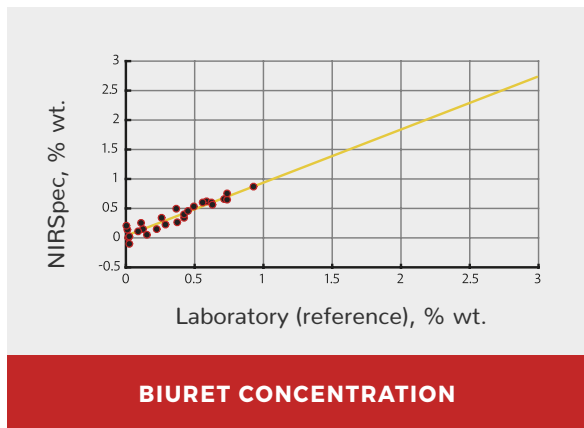
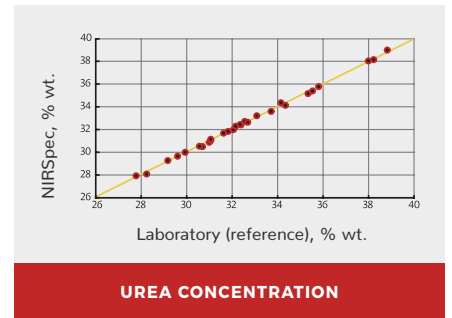
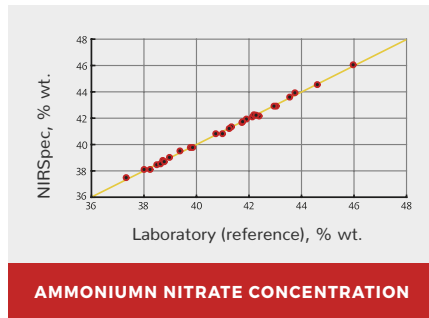
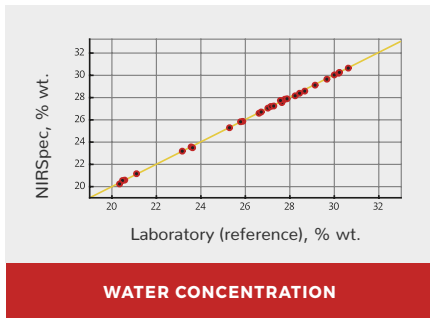

We developed a unique (PAT) solution for on-line analysis of UAN composition, which enables measuring not only the concentrations of the three main UAN components, namely: Urea, Ammonium Nitrate and Water, but also the concentration of the undesirable by-product Biuret, which is becoming an increasingly important quality parameter of UAN product.

Quantitative analysis of Biuret on-line is a particularly challenging problem, because the physical and chemical properties of the biuret molecule are similar/close to those of Urea. Therefore, analytical methods (PAT solutions) involving measurements such as conductivity, refractive index and density generally do not solve it satisfactorily. And, this is further complicated by typically low concentrations of Biuret in UAN.

We solved it and developed the state of the art calibration model capable of resolving not only the three main components but also biuret.

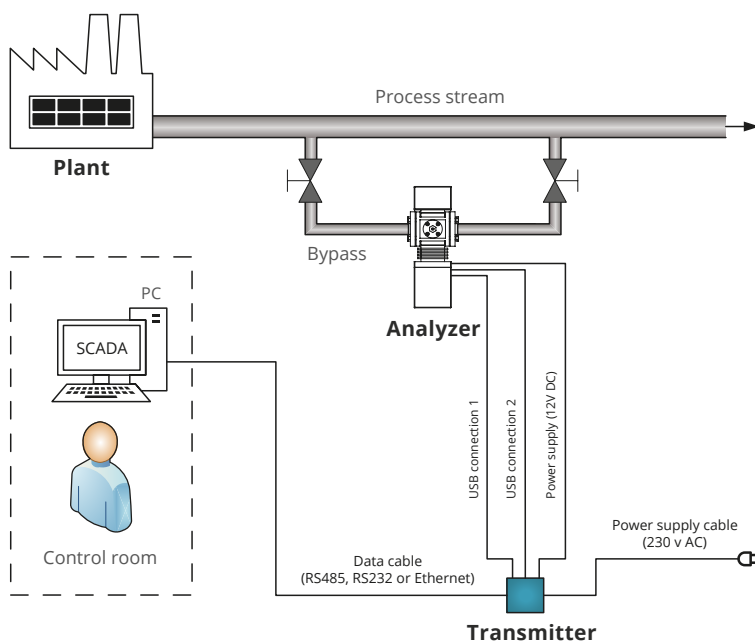

INSTALLATION

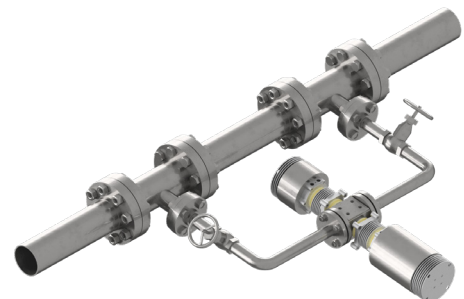

TECHNICAL SPECIFICATION

MODEL:	NIRSPEC
Measuring principle:	NIR absorption
Light source:	Halogen tungsten lamp
Optical path length:	from 1 to 30 mm
Illumination area/spot (diameter):	15 mm
Optical design:	single beam
Detector:	128 pixel InGaAs photodiode array
Wavelength range:	950÷1650 nm
Resolution:	10 nm
Material of optical windows:	Fused silica (other materials available)
Material of flow cell body:	stainless steel 316L (other materials available)
Connection to pipeline	Flanges DN32 PN10 to 40
Connecting pipeline diameter	from 35 to 45 mm
Interfaces:	MODBUS RTU/ASCII via RS485/RS232 MODBUS TCP/IP (via ethernet) MODBUS RTU via TCP (ethernet)
Processor:	Intel CPU
Dimensions:	168 x 168 x max 775 mm (length depends on a cooling type)
Weight:	26-30 kg (depends on a cooling type)
Power supply:	230 V AC
Power consumption:	120 W
Ambient temperature:	-15 to +40 °C
Sample temperature:	up to +160 °C
Pressure:	up to 10 bar
Relative humidity:	below dew point

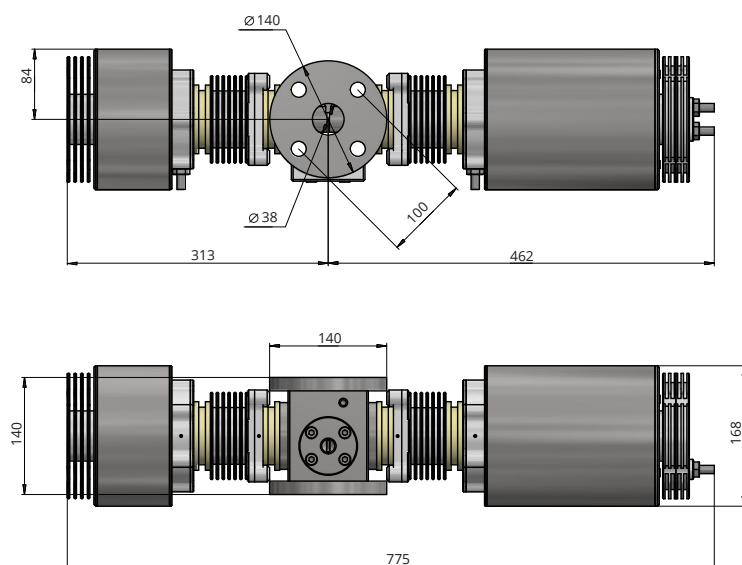

DRAWINGS